



Technical Data Sheet

ODX-AGM31M

- Group 31 with brass SAE posts, 3/8 inch positive and 5/16 inch negative thread SS stud terminals and single external vent
- Absorbed Glass Mat (AGM) with Thin Plate Pure Lead (TPPL)
- Advanced dual purpose battery for engine start and deep cycle use

Handling and Storage

- Can be mounted or stored in any orientation except inverted
- 2-years storage life at 77°F (25°C) without needing to charge. Recharge when the OCV is <12.2V (50% SOC).
- Classified as non-spillable and approved as non-hazardous cargo for ground, sea and air transportation in accordance with the requirements of IMDG (International Maritime code for Dangerous Goods) and ICAO (International Civil Aviation Organisation)

Charging and Self-Discharge

Cyclic Charge Voltage	14.4 - 14.8V @ 25°C
Float Charge Voltage	13.5 - 13.8V @ 25°C
Charger voltage at 68°F (20°C)	14.4V to 14.8V
Self-discharge per month at 68°F (20°C)	1.25%
Self-discharge per month at 104°F (40°C)	5%
80% depth of discharge cycles	400

Accreditations

The management systems governing the manufacture of this product are ISO 9001 and ISO 14001 certified.

*Cold Start Performance S.A.E J537 Apr 2016

Power and Performance

Voltage	12V
Pulse (5 second) Hot Cranking Amps (PHCA)	2150A
MHPCA	1950A
MPCA	1625A
Cold Cranking Amps (CCA)	1150A
HCA	1545A
MCA	1370A
20Hr Nominal Capacity (Ah)	103Ah
10Hr Nominal Capacity (Ah)	98Ah
Reserve Capacity Minutes	220 mins
Terminal	SAE and 3/8-16" Stud (Pos.), 5/16-18" Stud (Neg.)
Torque Spec in-lbs (Nm max)	200 (22.6)/100 (11.3) studs only
Internal Resistance (mΩ)	2.2 mΩ
Short Circuit (A)	5000A
Recommended Min. Charging Current (A)	9.8A
UPC	635241140675

Dimensions and Weight

Length	13 in / 330 mm
Width	6.8 in / 173 mm
Height (terminals included)	9.9 in / 251 mm
Height (container)	8.9 in / 226 mm
Weight	77.8 lbs / 35.3 kg

See Line Drawing on next page

Temperature

Operating temperature range	-40°F / -40°C to 176°F / +80°C
Optimum storage temperature	68°F / +20°C

Technical Data Sheet correct at time of exporting PDF. Please check website for updates.



EnerSys World Headquarters
2366 Bernville Road
Reading, PA 19605, USA
Tel: +1-800-964-2837

EnerSys EMEA
EH Europe GmbH
Baarerstrasse 18
6300 Zug, Switzerland

EnerSys Asia
No. 85, Tuas Avenue 1
Singapore 639518
Tel: +65 6558 7333

Want more info?
Scan code to access
the ODYSSEY[®] Battery
Literature Library



Line Drawing

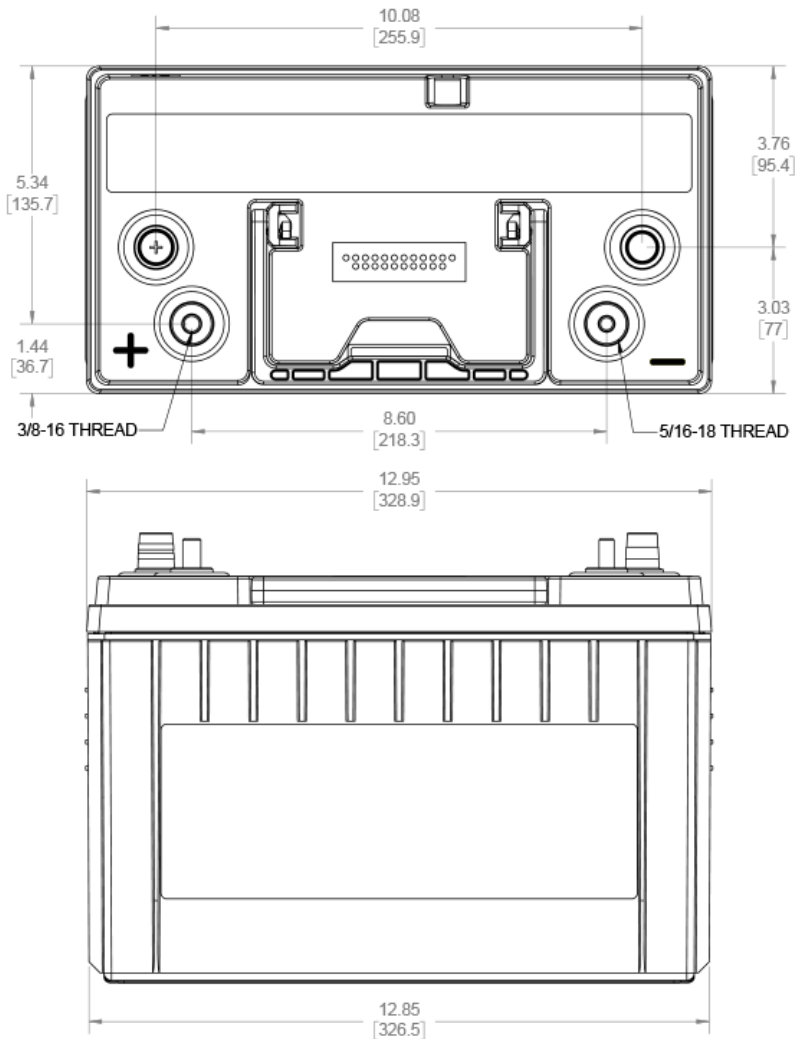

**ODX-AGM31M
LEFT POSITIVE
DUAL TERMINALS
(SAE & STUD)**

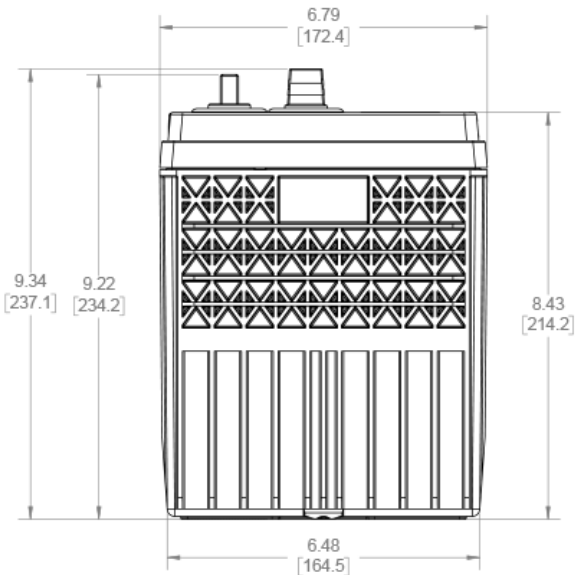

ODYSSEY batteries – AGM² Thin Plate Pure Lead (TPPL) Technology

ODYSSEY[®] AGM² Thin Plate Pure Lead (TPPL) batteries feature 99% pure lead plates that are extremely thin, so more of them fit into the battery. More plates mean more power – ODYSSEY AGM² TPPL batteries deliver twice the power and three times the service life of any other conventional battery, outperforming standard AGM or SLI (flooded) batteries in terms of power density, fast-charge acceptance, shelf life, durability and most important – value for your money.

Technical Data Sheet correct at time of exporting PDF. Please check website for updates.



EnerSys World Headquarters
2366 Bernville Road
Reading, PA 19605, USA
Tel: +1-800-964-2837

EnerSys EMEA
EH Europe GmbH
Baarerstrasse 18
6300 Zug, Switzerland

EnerSys Asia
No. 85, Tuas Avenue 1
Singapore 639518
Tel: +65 6558 7333

Want more info?
Scan code to access
the ODYSSEY[®] Battery
Literature Library

